



XP Unit

**xp
unit**

xpunit.com

[@xp_unit](mailto:xp_unit)

roman@units.team

06.68.78.74.94



XP Unit is a creative agency designing sensory experiences through art, technology, robotics and design.



**We create interactive,
robotic and luminous
devices, putting the
public at the heart of
events.**



References

Audi
Adidas
BNK
Double 2
Compagnie Les Bâtards Dorés
Grand Palais
La Caserne
Madd-bordeaux
Palais de Tokyo,
Point Éphémère
RAW Agency,
Togæther
Réunion des Musées Nationaux.

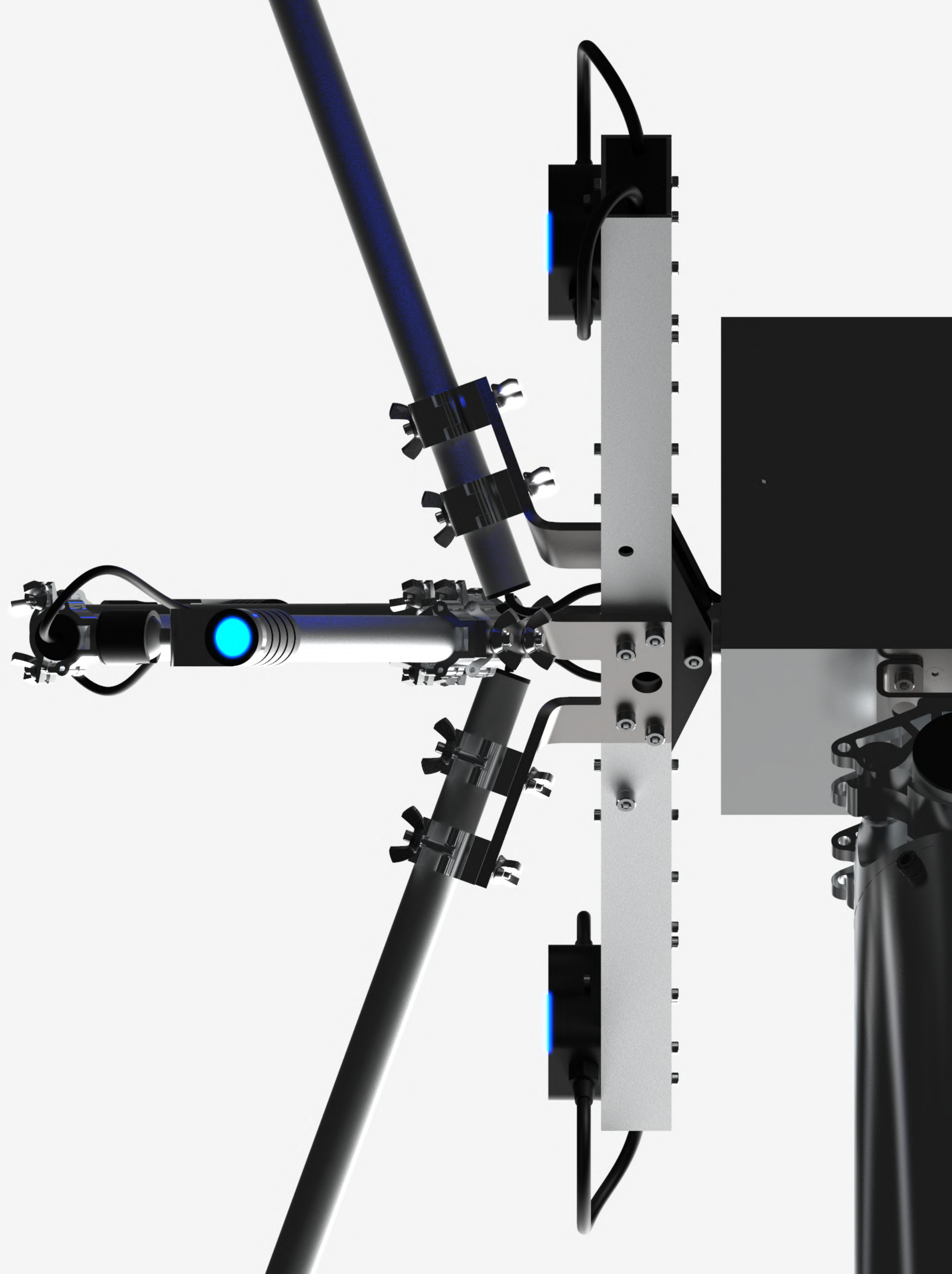

BRIEF

Creating a immersive space highlighting Audi's technology excellence.

**A 300 sq m room
between a theme park
and a futuristic rave.**

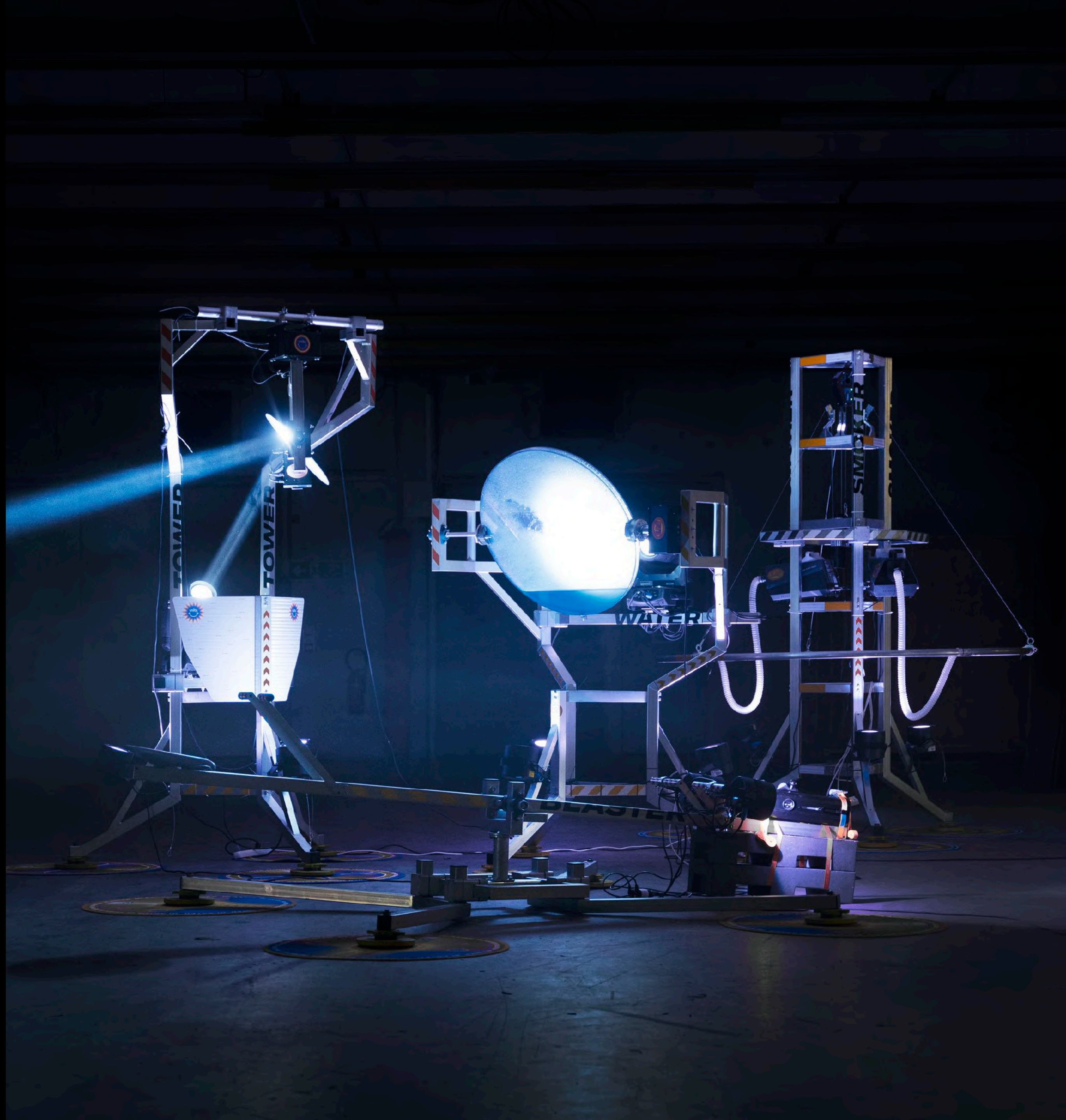

**PALAIS
DE TOKYO**

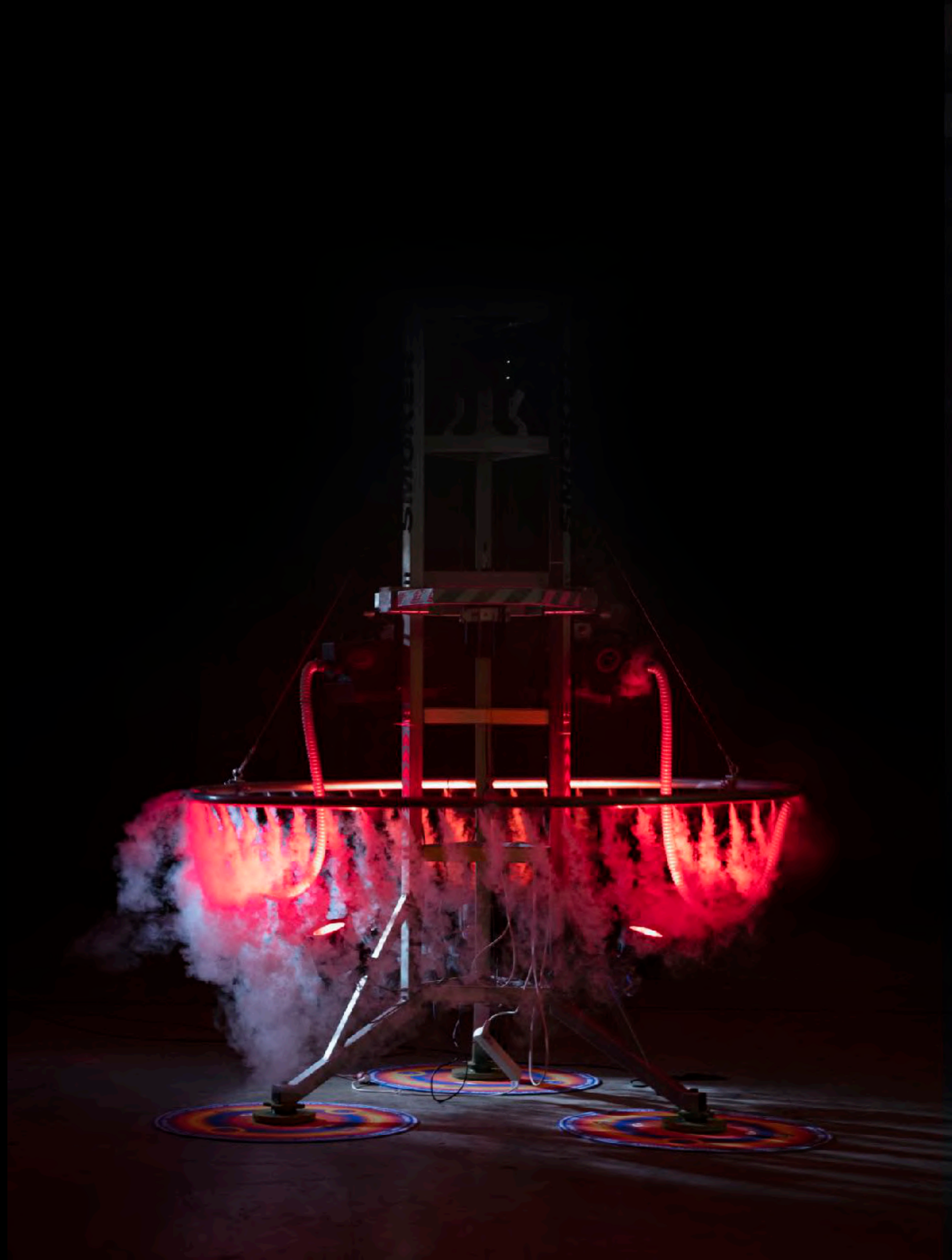



BRIEF

Designing a stage for livestream concerts into the nave of the Grand Palais.

A Light & Sound installation showcasing the nave of the Grand Palais and the musicians.

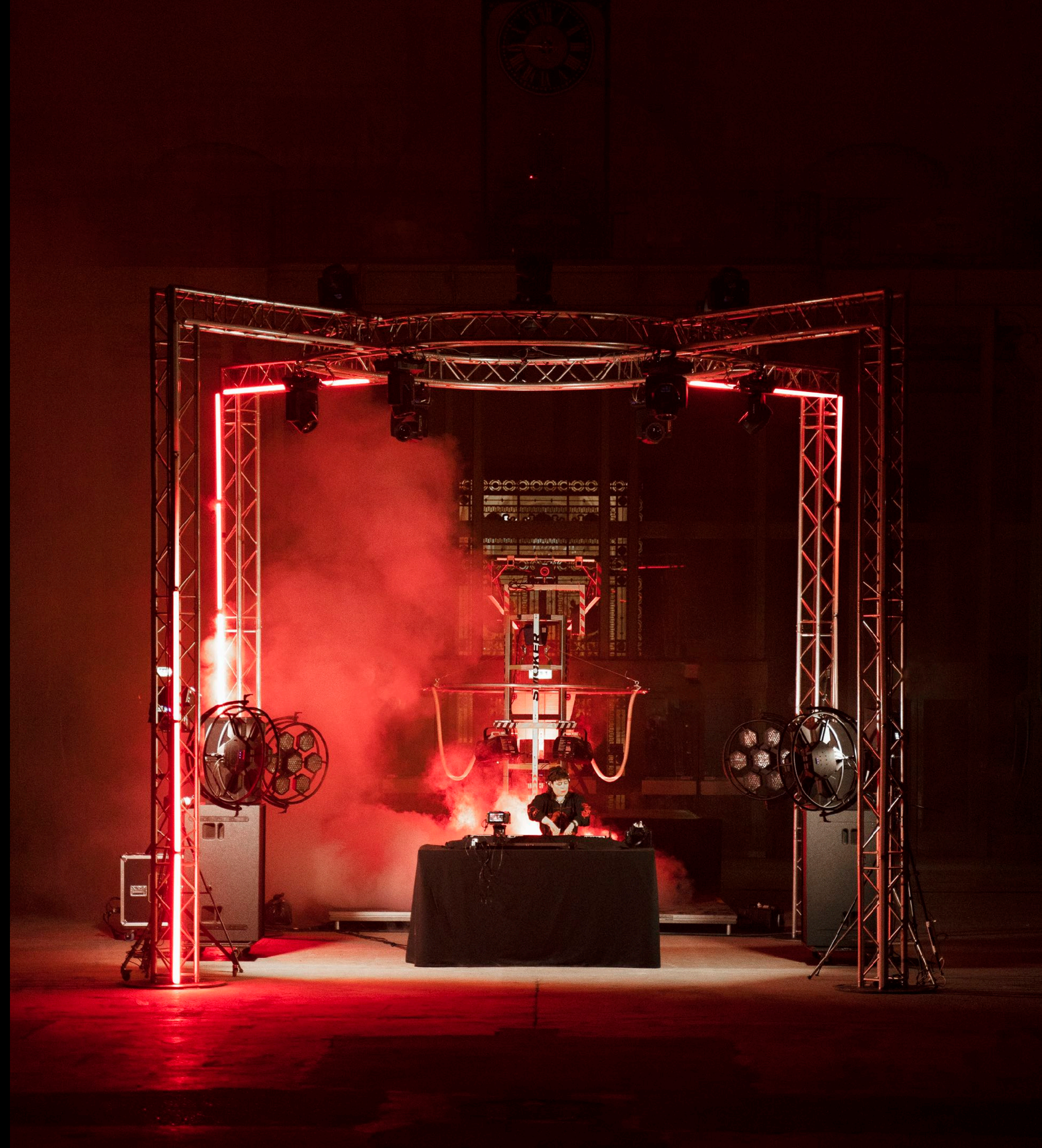



BRIEF

Create one month of events and exhibition for the madd-bordeaux.

A technical and smoke environment made for an old prison space in Bordeaux.

*musée des
arts
décoratifs*
*musée
du design
bordeaux*

fimeb



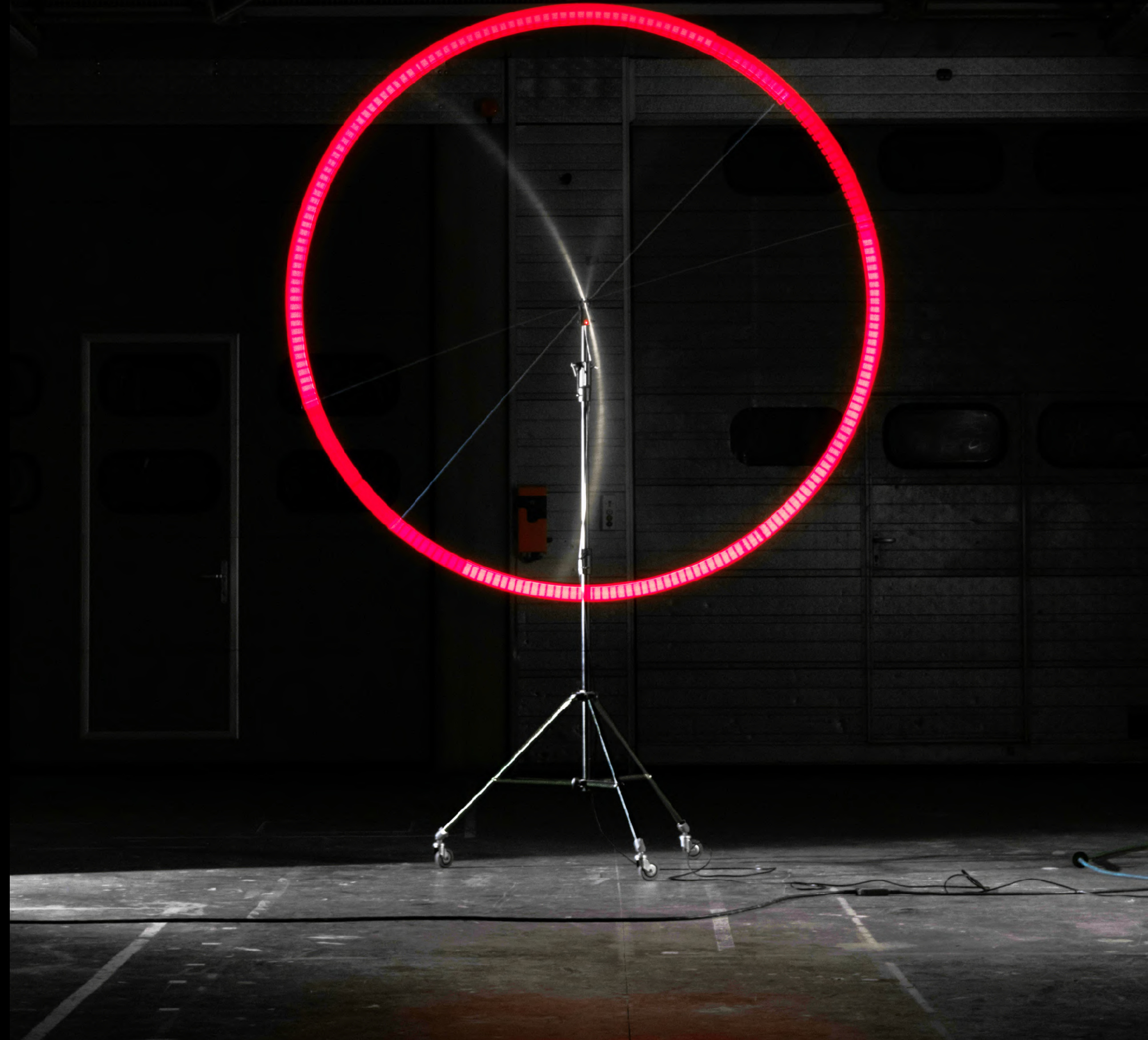
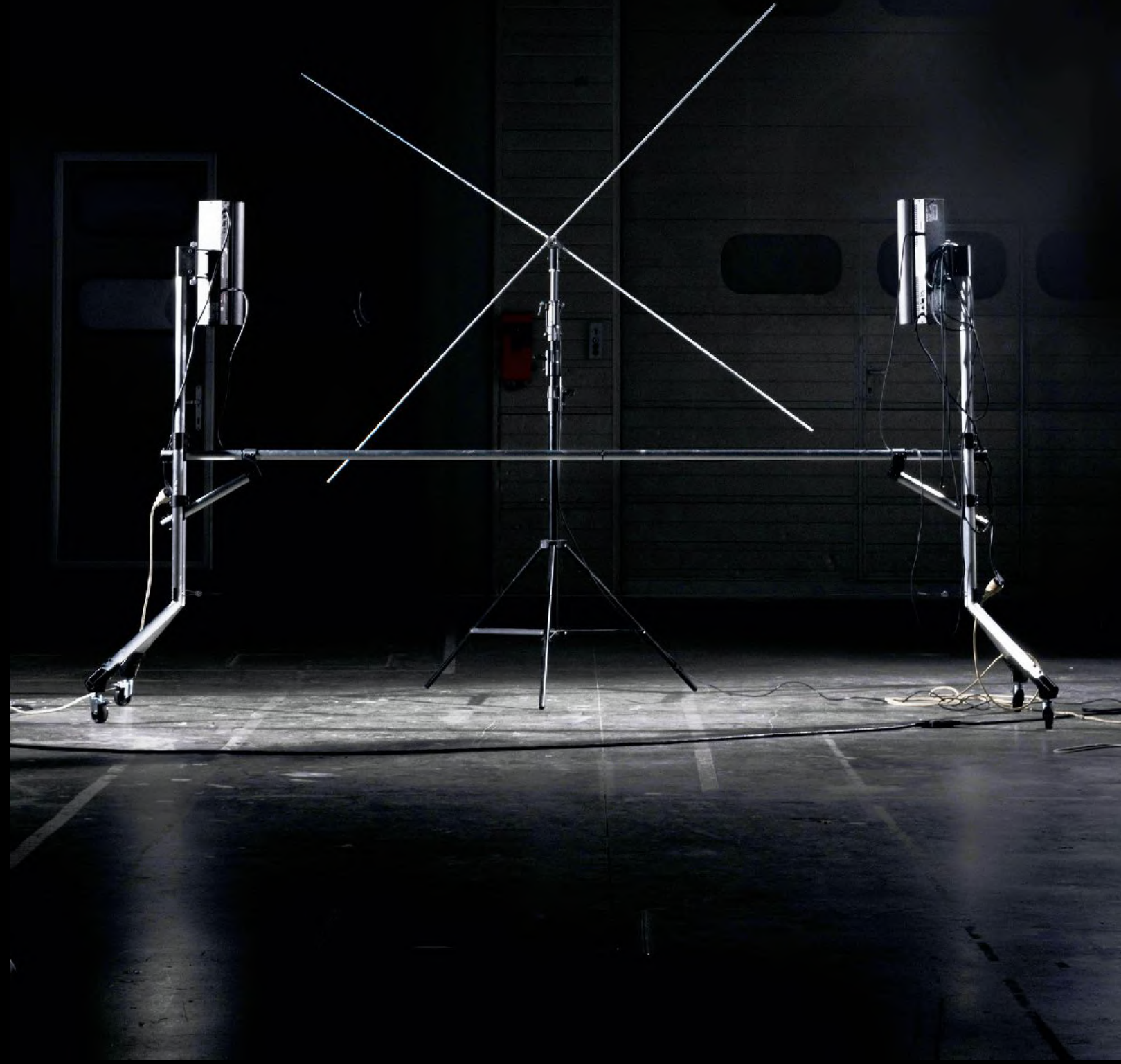



BRIEF

Create a device to signal the entrance of La Caserne Nightclub.

A smoke entrance for La Caserne Nightclub imitating fire effects.





BRIEF

Create a device imaging the natural environment for Terrex Collection

An invisible system creating mist inside the Adidas Flagship store in Paris





Skills and services

SET DESIGN

for PHOTOGRAPHY / VIDEO / CATWALKS.

CUSTOM DESIGN

DESIGN and PRODUCTION of devices
highlighting brands philosophy.

VIRTUAL SET DESIGN

CGI ANIMATIONS or IMAGES for BRAND
COMMUNICATION.



Thanks !

XP Unit

**xp
unit**

xpunit.com

[@xp_unit](mailto:xp_unit)

roman@units.team

06.68.78.74.94

